

Lid Top View

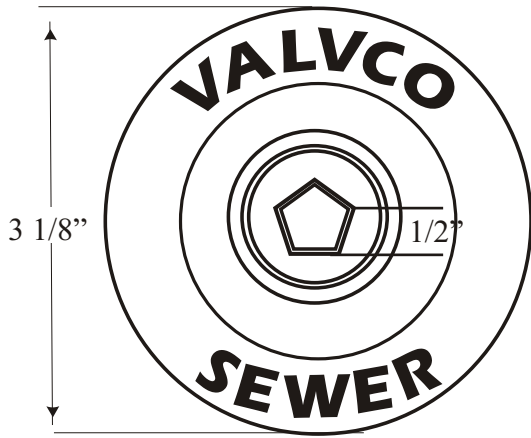

Complete Box Side View

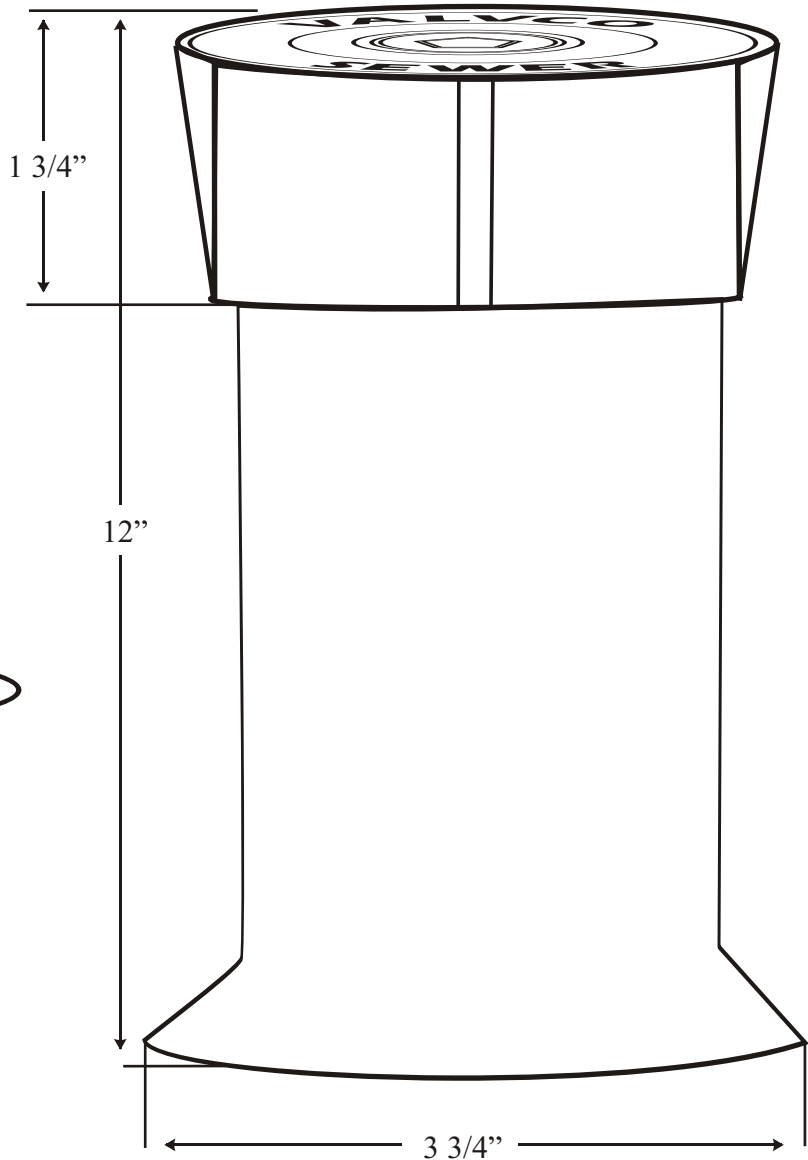

Lid Side View

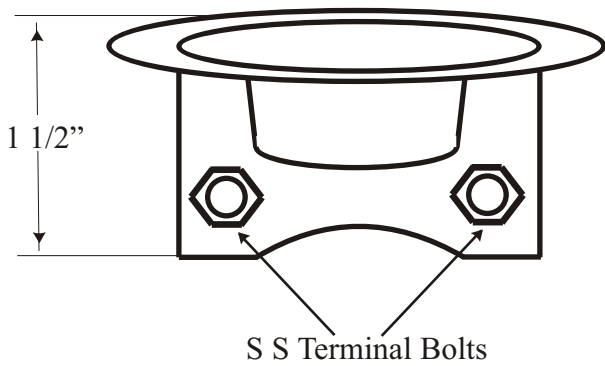

Collar Top View

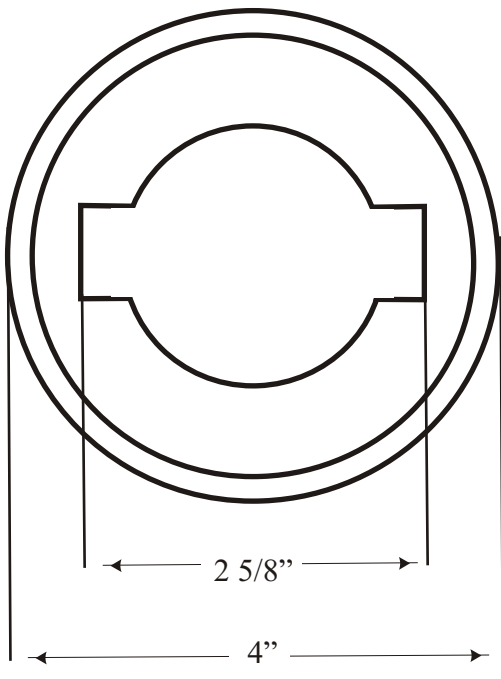

Figure # SEWAB
Sewer Tracer Wire Access Box

Casting conforms to:
ASTM specification A-48 Class 30
Country of Origin: USA

ABS conforms to:
ASTM specification D1788
Country of Origin: USA

C.P. Test Services - Valvco, Inc.

Lid Top View

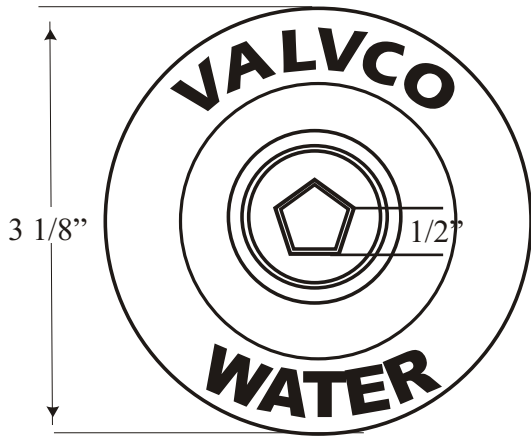

Lid Side View

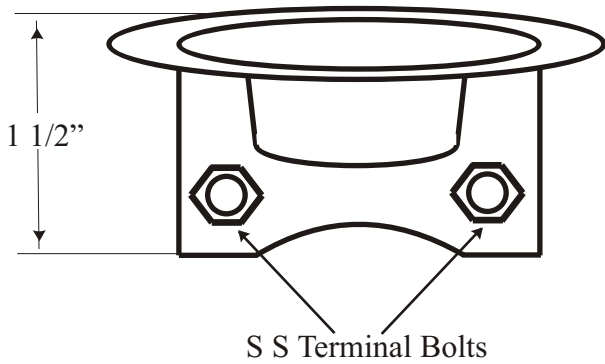

Collar Top View

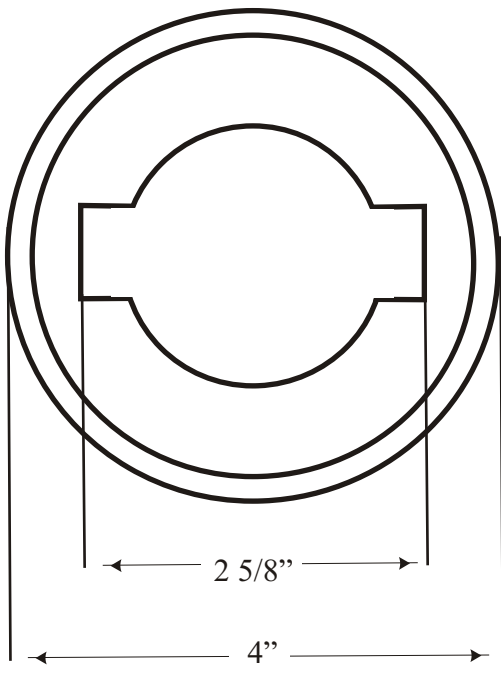

Complete Box Side View

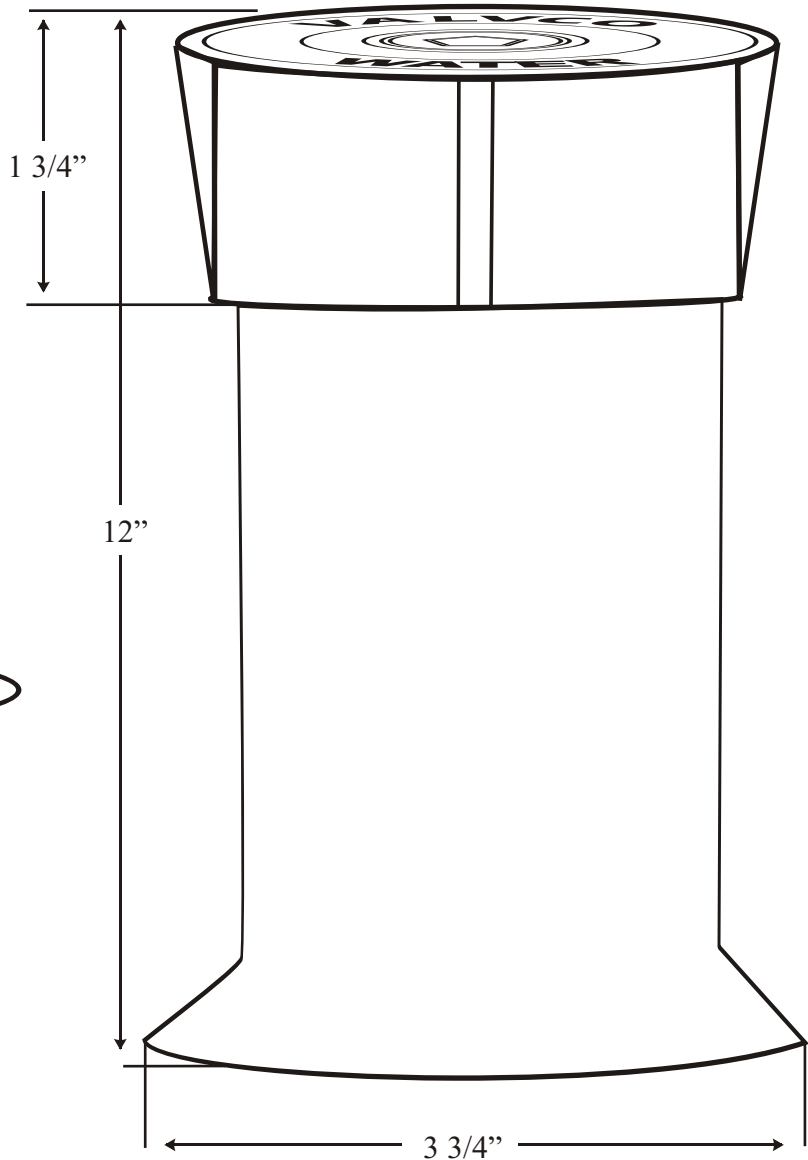

Figure # TWAB
Water Tracer Wire Access Box

Casting conforms to:
ASTM specification A-48 Class 30
Country of Origin: USA

ABS conforms to:
ASTM specification D1788
Country of Origin: USA

C.P. Test Services - Valvco, Inc.

Lid Top View

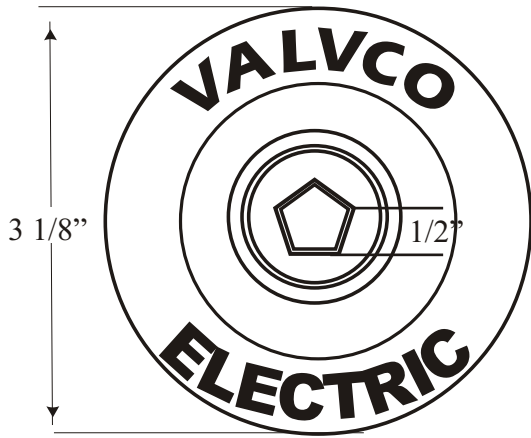

Lid Side View

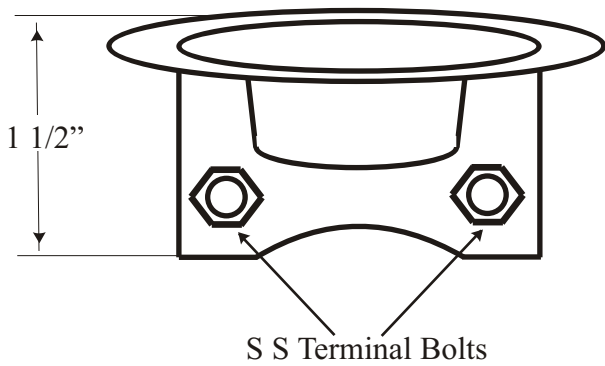

Collar Top View

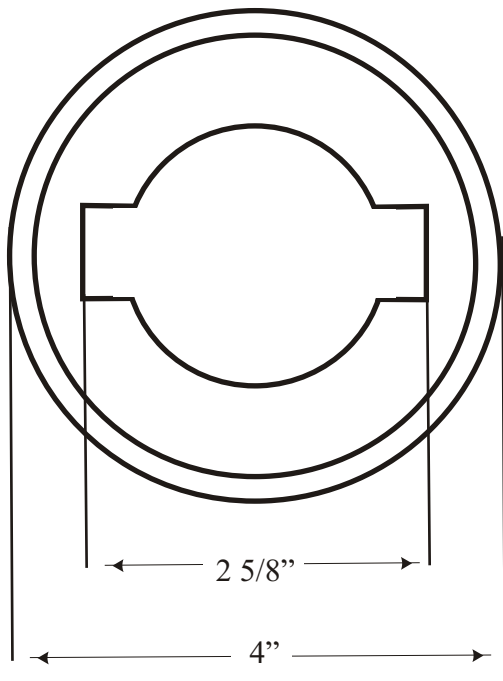

Complete Box Side View

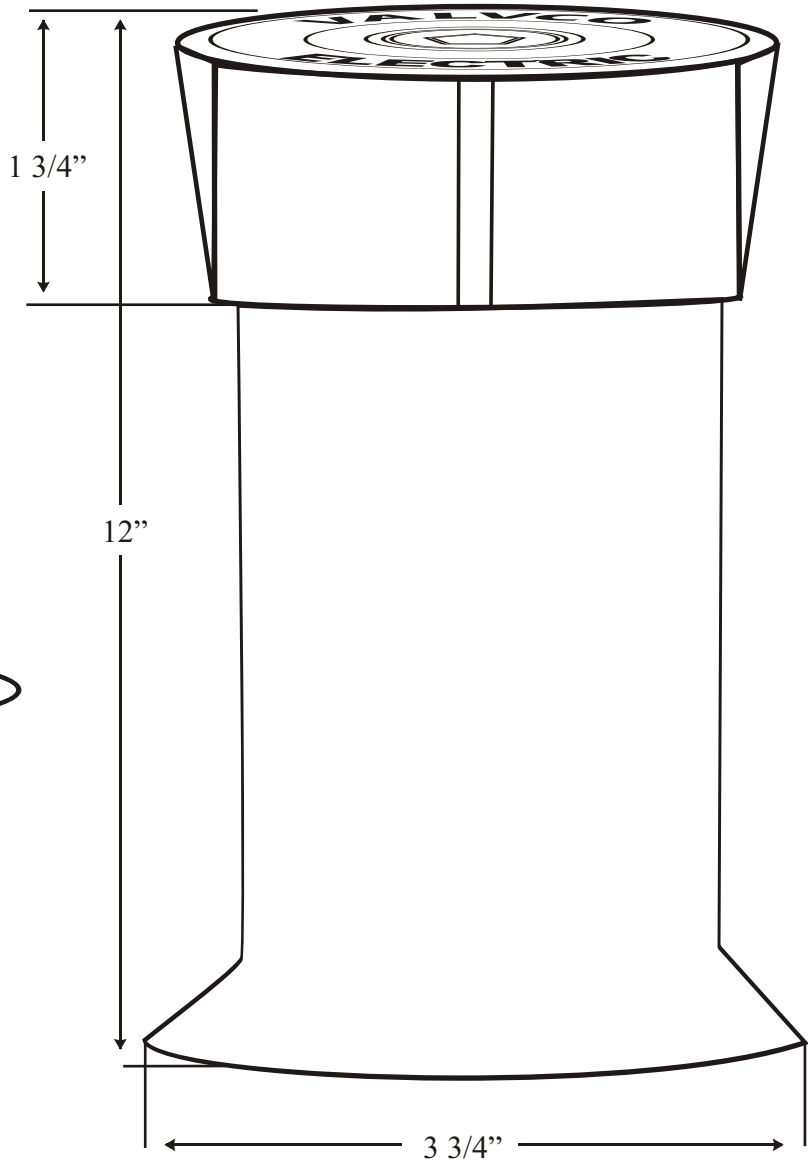

Figure # ELAB
Electric Tracer Wire Access Box

Casting conforms to:
ASTM specification A-48 Class 30
Country of Origin: USA

ABS conforms to:
ASTM specification D1788
Country of Origin: USA

C.P. Test Services - Valvco, Inc.

Lid Top View

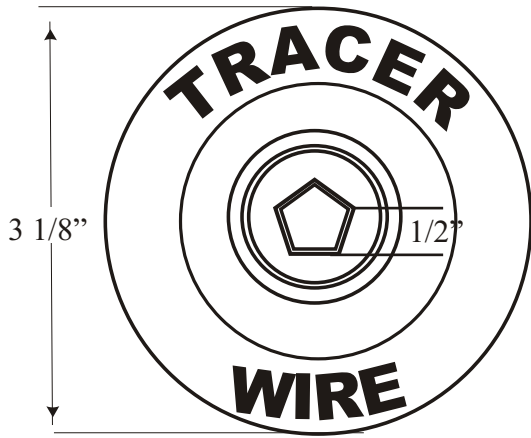

Lid Side View

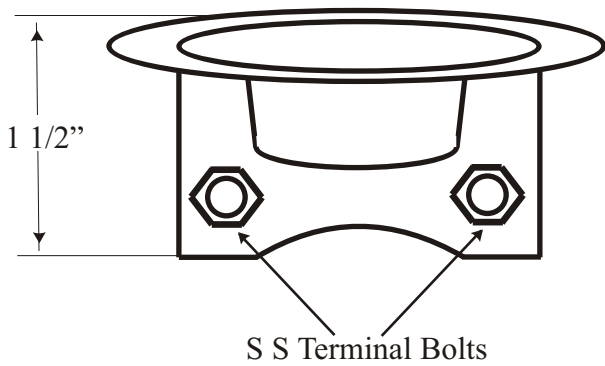

Collar Top View

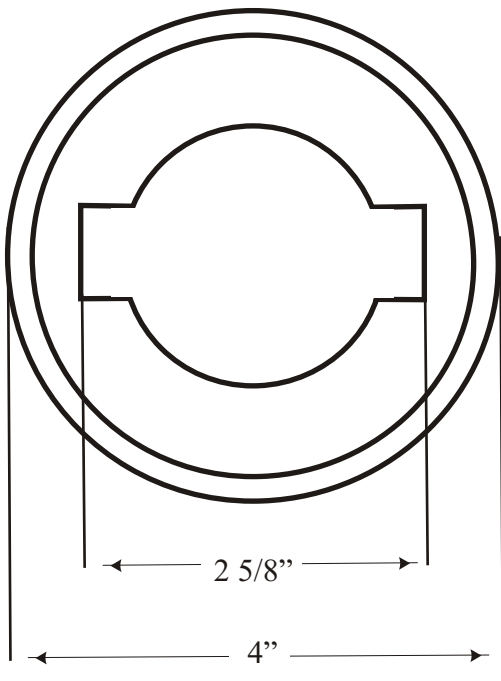

Complete Box Side View

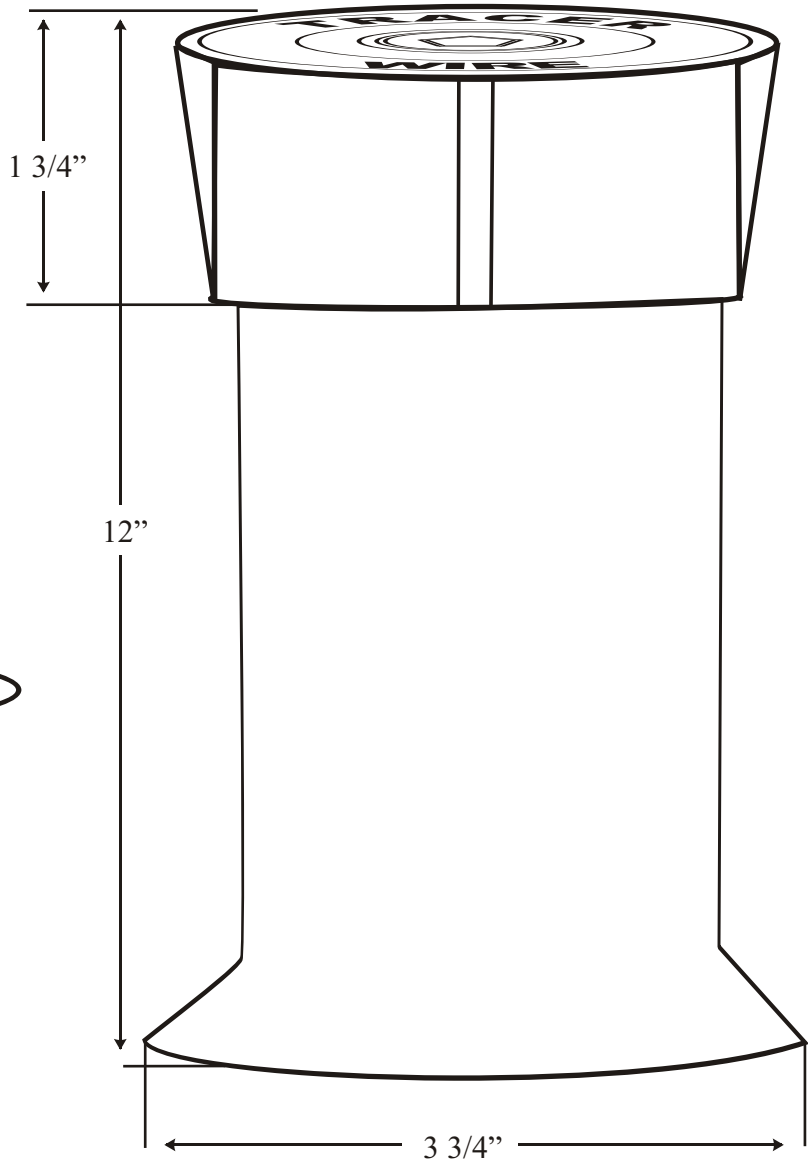

Figure # TRAB
Tracer Wire Access Box

Casting conforms to:
ASTM specification A-48 Class 30
Country of Origin: USA

ABS conforms to:
ASTM specification D1788
Country of Origin: USA

C.P. Test Services - Valvco, Inc.

Lid Top View

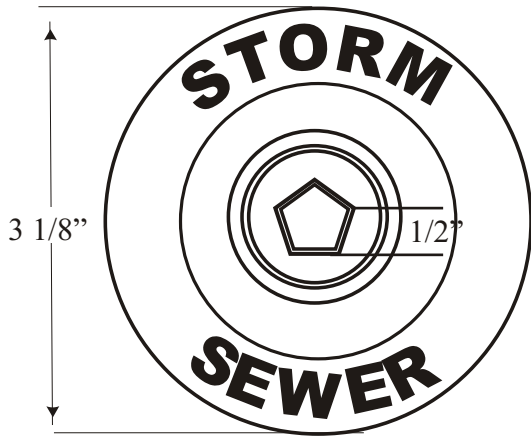

Complete Box Side View

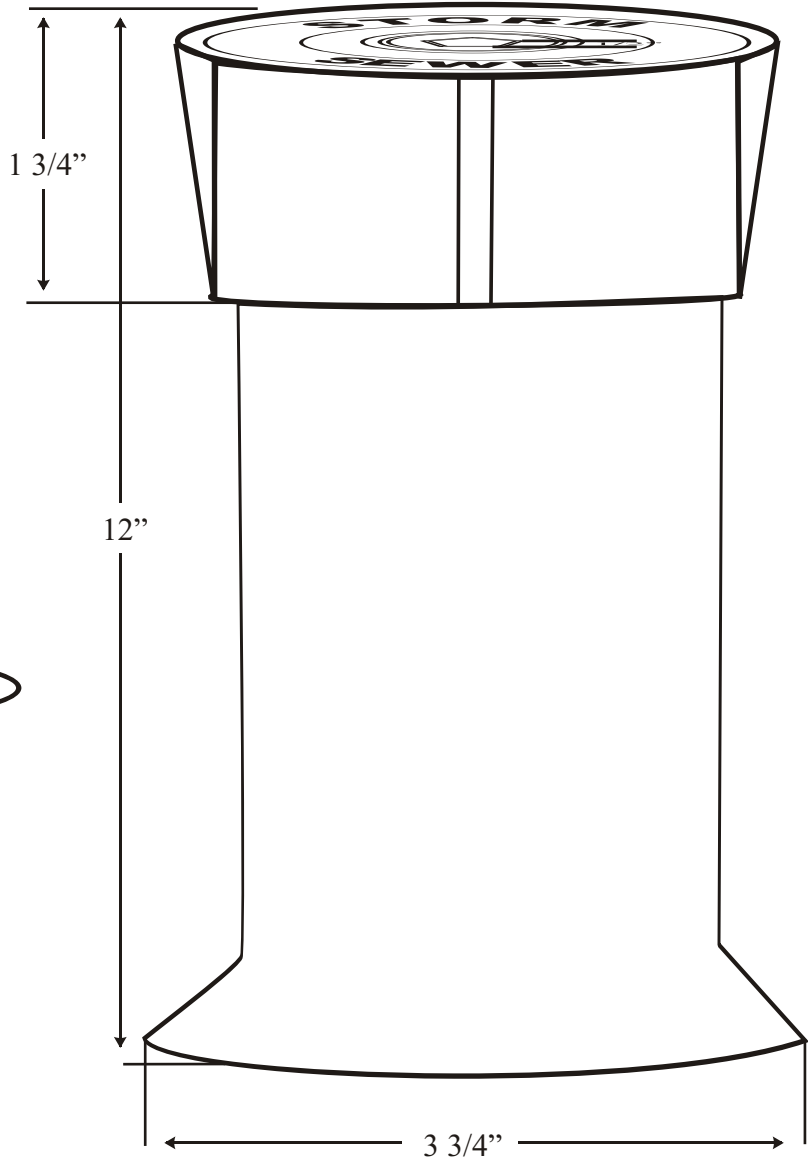

Lid Side View

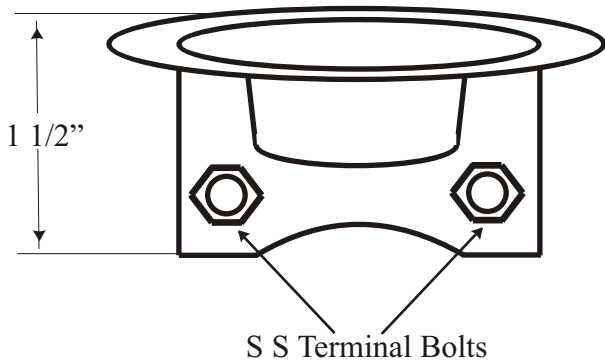

Collar Top View

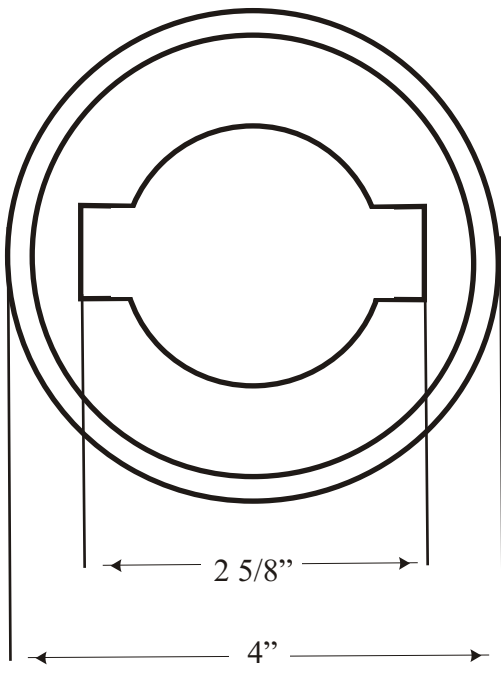

Figure # SSAB
Storm Sewer Tracer Wire Access Box

Casting conforms to:
ASTM specification A-48 Class 30
Country of Origin: USA

ABS conforms to:
ASTM specification D1788
Country of Origin: USA

C.P. Test Services - Valvco, Inc.

Lid Top View

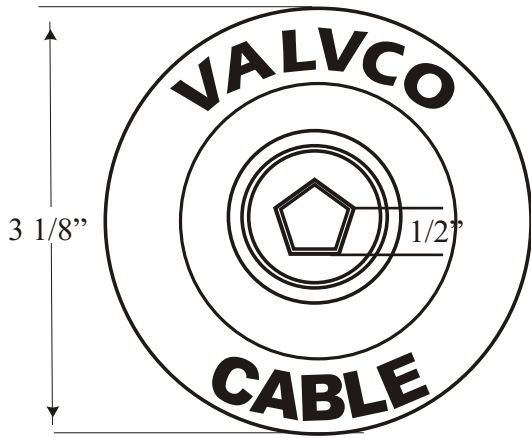

Complete Box Side View

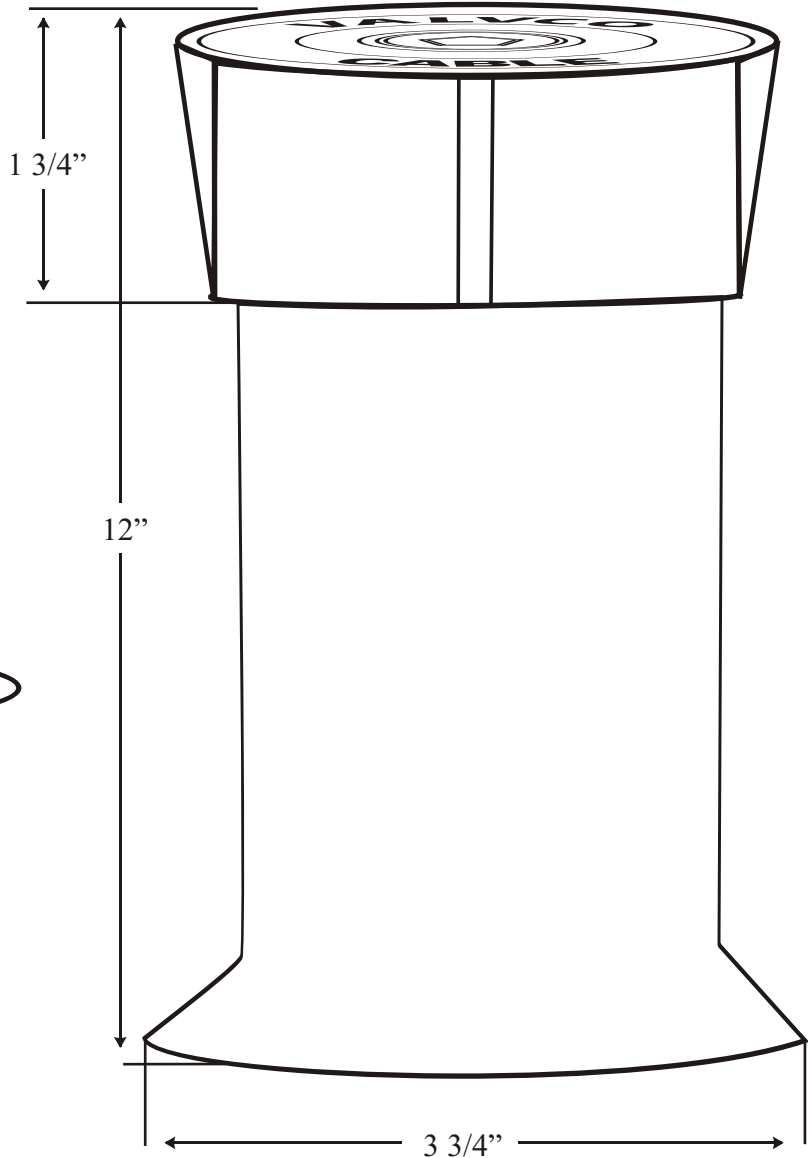

Lid Side View

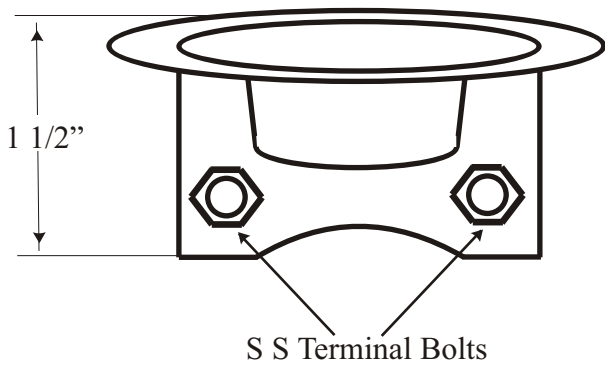

Collar Top View

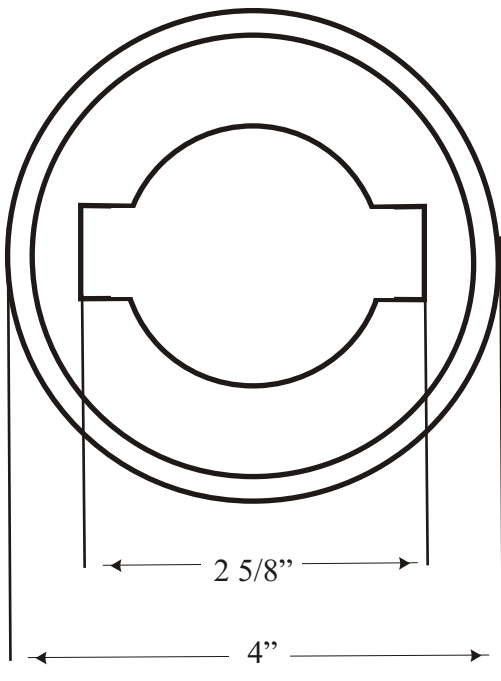

Figure # CAB
Cable Tracer Wire Access Box

Casting conforms to:
ASTM specification A-48 Class 30
Country of Origin: USA

ABS conforms to:
ASTM specification D1788
Country of Origin: USA

C.P. Test Services - Valvco, Inc.

Lid Top View

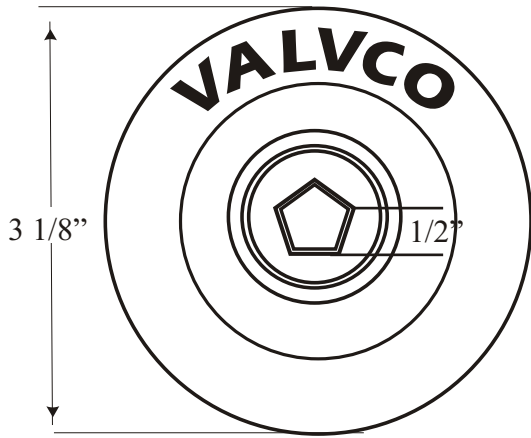

Lid Side View

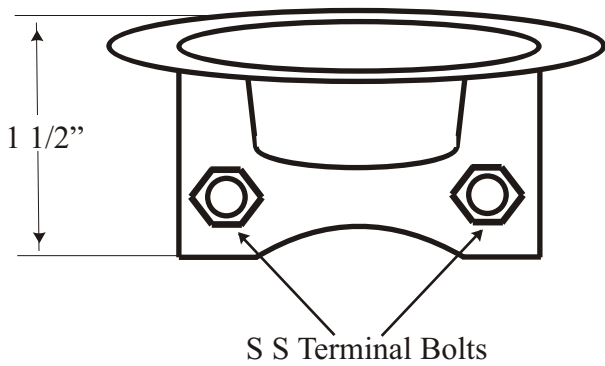

Collar Top View

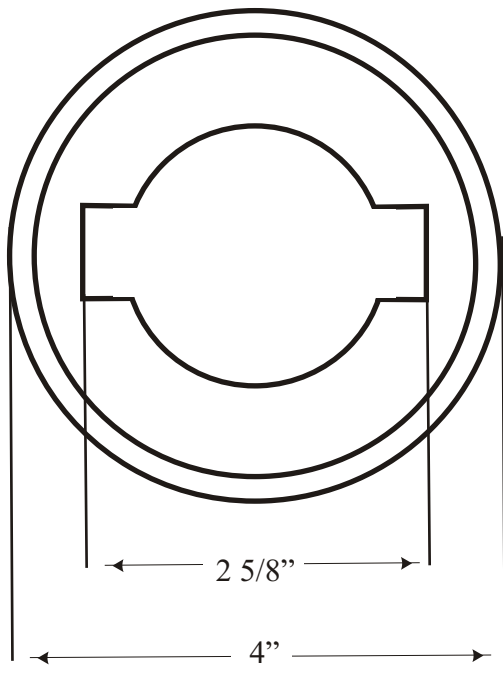

Complete Box Side View

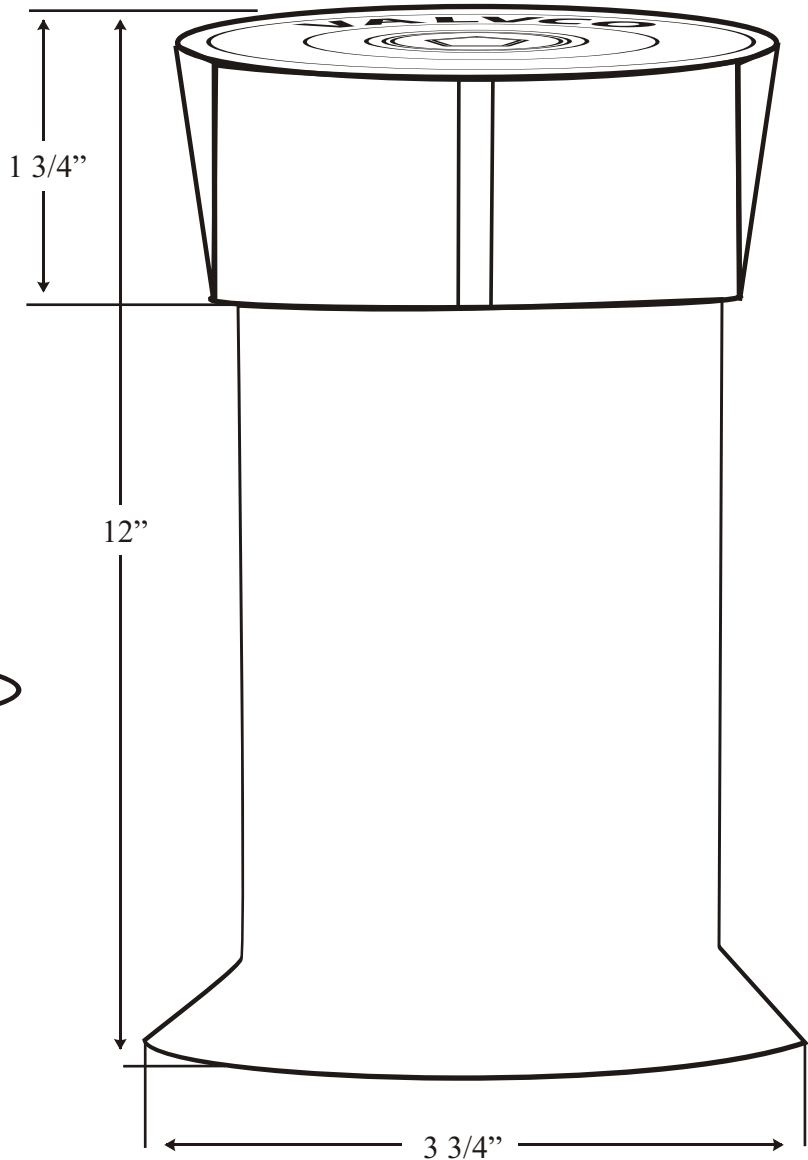

Figure # PAB
Plain Tracer Wire Access Box

Casting conforms to:
ASTM specification A-48 Class 30
Country of Origin: USA

ABS conforms to:
ASTM specification D1788
Country of Origin: USA

C.P. Test Services - Valvco, Inc.

Lid Top View

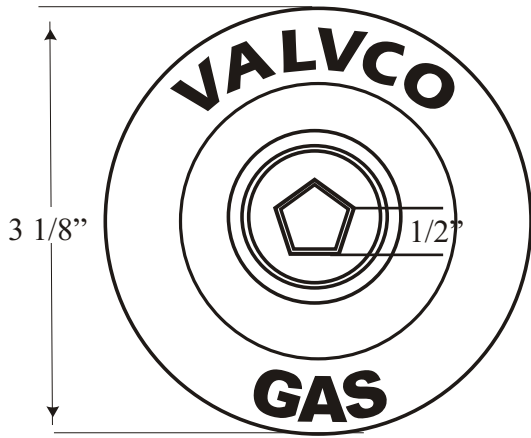

Complete Box Side View

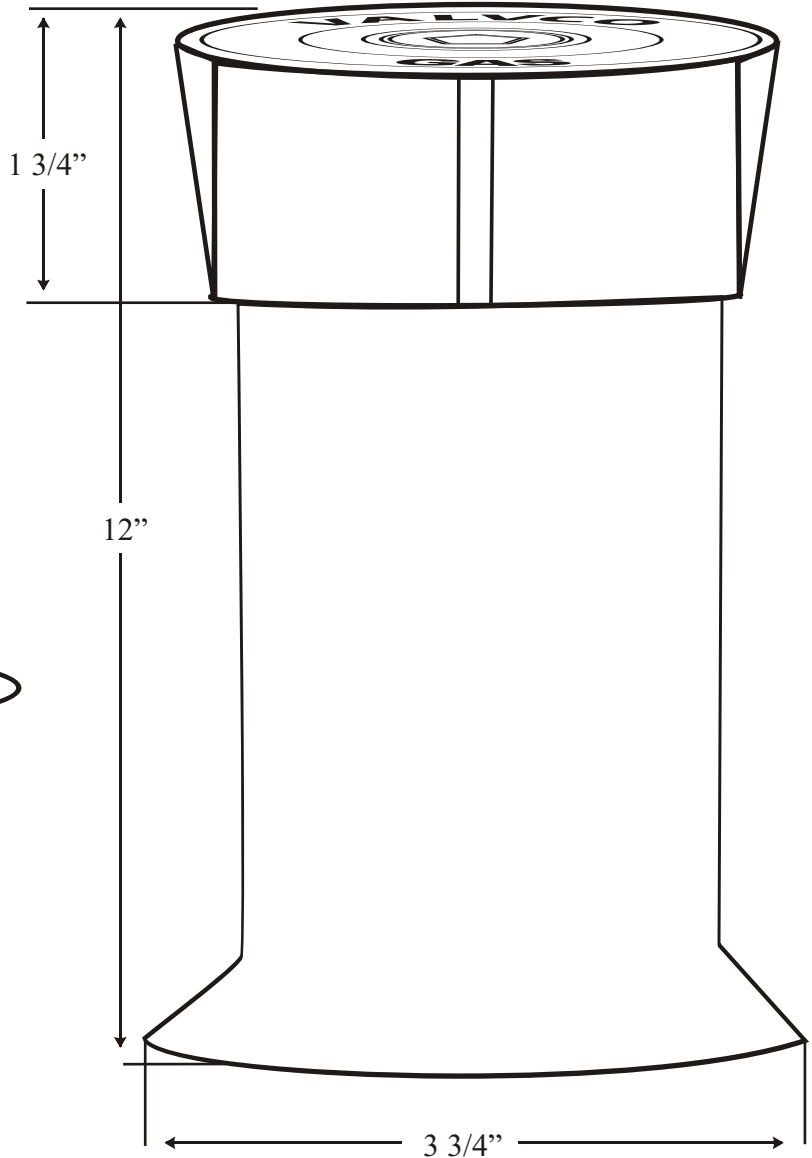

Lid Side View

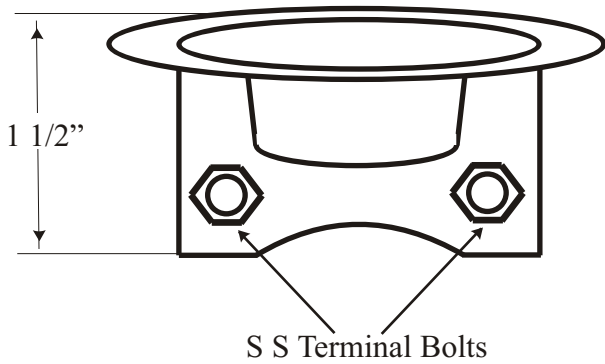

Collar Top View

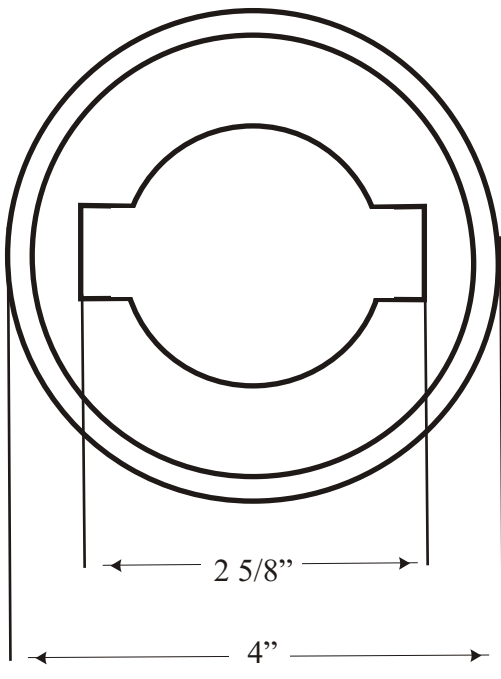

Figure # GAB
Gas Tracer Wire Access Box

Casting conforms to:
ASTM specification A-48 Class 30
Country of Origin: USA

ABS conforms to:
ASTM specification D1788
Country of Origin: USA

C.P. Test Services - Valvco, Inc.